



NEILL LAURENSEN

KINGSMAN PM

PORTFOLIO

March 2026



"The enemy of creativity is good sense" - Picasso



Aged care
Civil Infrastructure
Commercial
Civil Marine
Defence
Education
Entertainment
Exclusive residential
Food & beverage
Golf Estates
Healthcare
Highrise
Hotels
Meat works
Modular
Remote Communities
Renewables
Residential
Security
Sports/Recreation
Superyachts
Tourism
Wineries

"Neill Laurenson has over his 38-year career worked on a vast array of projects and industries; all of this experience has ended up with him being labeled as an 'Expert Generalist' which is very fitting as he has achieved several World Firsts. If you have a project that is different, vital and or significant any way, we recommend that you consider engaging him to deliver your project for you." – Private Client



- **ROY HILL NEW HEADQUARTERS – Neill Laurenson - Project Manager**

- **Project Overview**

- The development is a multi-site initiative anchored around **53 Ord Street**, West Perth, and is estimated to cost approximately **\$250 million**.
- Key features include:
- **Corporate Headquarters:** The site at 53 Ord Street is being transformed into a high-tech hub for Roy Hill and Hancock Prospecting, shifting operations from Perth Airport.
- **Pink Kinetic Façade:** A standout architectural feature is a pink "kinetic" façade made of petal-shaped fins, designed as a tribute to **breast cancer awareness**.
- **Expansion:** The project encompasses a roughly 6,000–7,000 square metre footprint bordered by **Ord Street**, **Outram Street**, **Ventnor Avenue**, and **Richardson Street**.
- **Amenities:** Planned facilities include a rooftop helipad, a wellness centre (feline-friendly), childcare, a "town hall" Amphitheatre, and landscaped terraces



Hancock Iron Ore
New Headquarters – Ord St. Subiaco
Neill Laurenson – Construction and Fit out Project Manager















Wharf extensions and associated vessel movement infrastructure – Perth WA



Certified -
International Protect & Prepare Security Officer -
Certificate, Security & Terrorism Threat Analysis



Soft Target Counter Terrorism Planning And Security
Countermeasures Awareness.
(External entry / fitout design)



Remote Communities

New Build pre-planning Upgrades and infrastructure



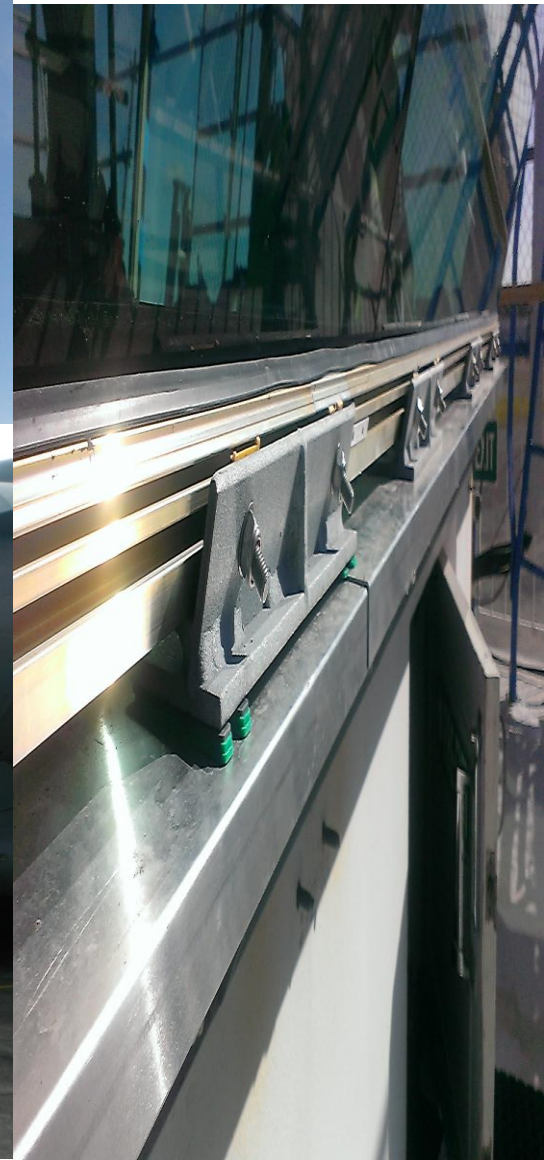

NZDF – various projects for Army and Air Force



VARIOUS PROJECTS - Concrete works - Precast and in situ and offsite.



AMC HENDERSON SUPERYACHT SITE



HAMASAKI RESIDENCE – TERRACE DOWNS.
Eight bedrooms and Japanese bath suite, built in honour of Mr Hamasaki's daughter Yuki who died in the Christchurch earthquake





WIND ASSISTED CARGO VESSEL DESIGNS IN CONJUNCTION WITH STEVE KOZLOFF DESIGNS- [LINK](#)

**MILITARY: BTF /
RANGES /
ELECTRONIC
RANGES
DEFENCE
INFRASTRUCTURE**



**DEFENCE
INFRASTRUCTURE**



Assembly of a proposal between the Rowe Group & MRCB for the East Perth Power Station redevelopment to Development WA. (Confidential & Pending)

The logo for MRCB, with the letters 'M', 'R', and 'C' in blue and 'B' in red, all in a bold, sans-serif font.

MRCB





CRANMER GARDENS REBUILD PROJECT



STEENBERG WINERY



HOLLY LEA RETIREMENT APARTMENTS CHRISTCHURCH

- o Russley Village Christchurch
- o Silvermine Village cape Town



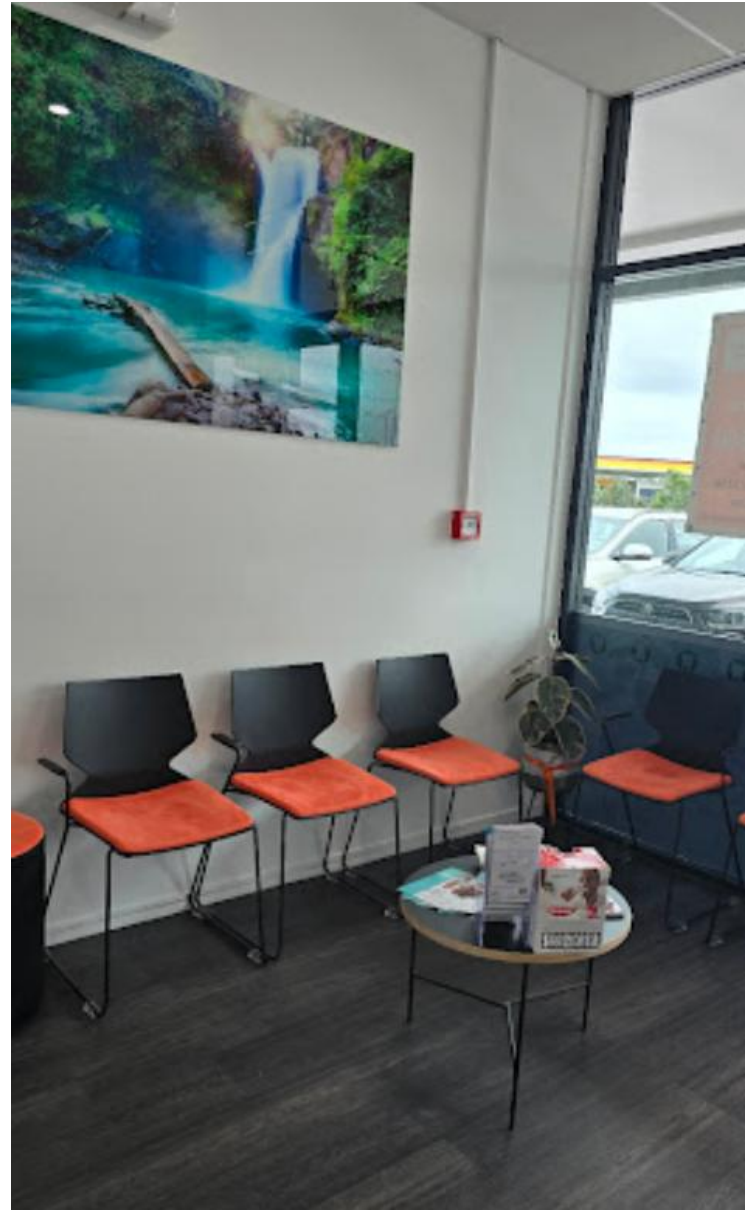



HREF – 7 FLOOR NURSES TRAINING CENTRE CHRISTCHURCH for
University of Canterbury / Univ. Otago

Full Design / Build PM and Engineer to the Contract role – Client side

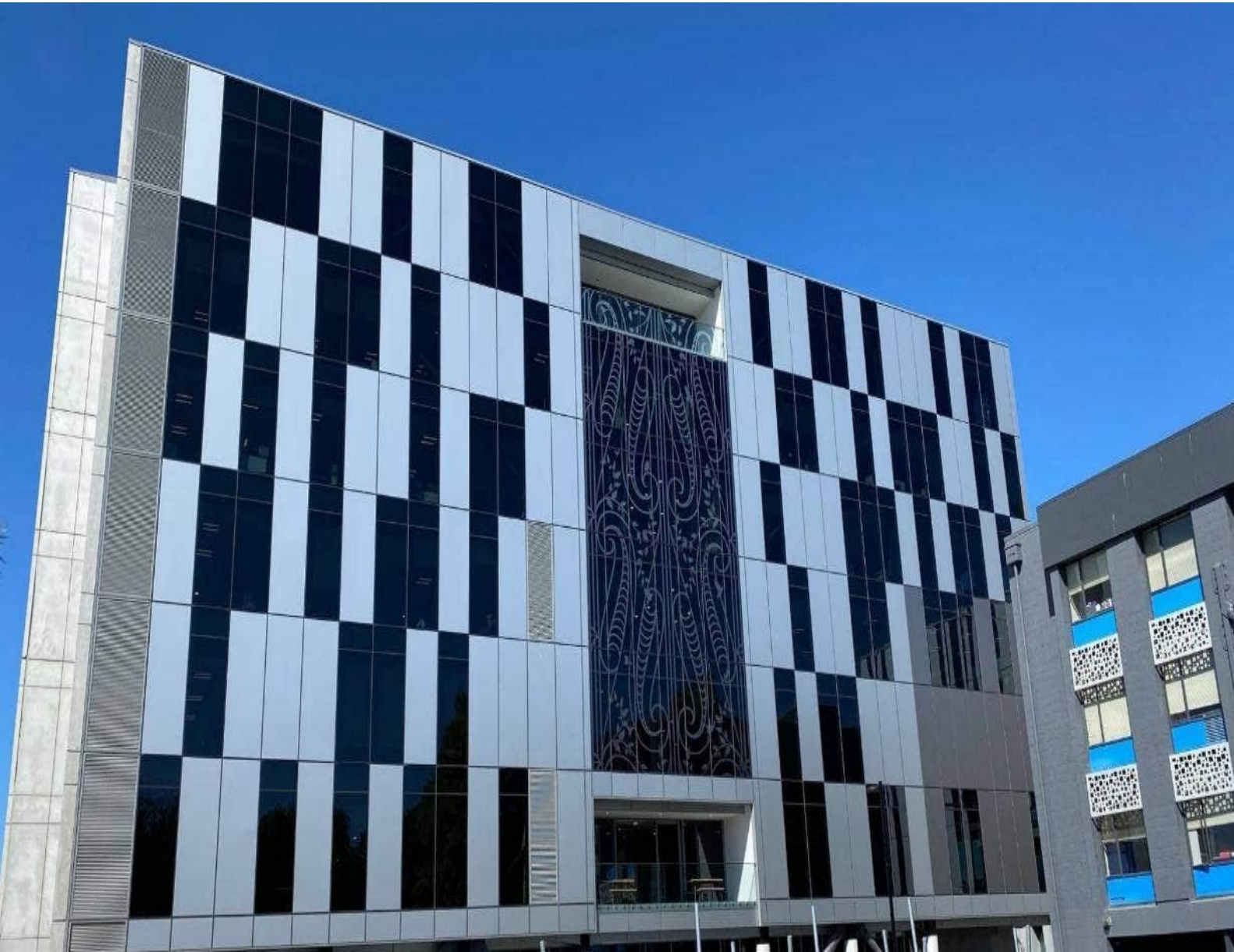



THE GOLIATH SERIES
POLAR CLASS
EXPEDITION YACHTS

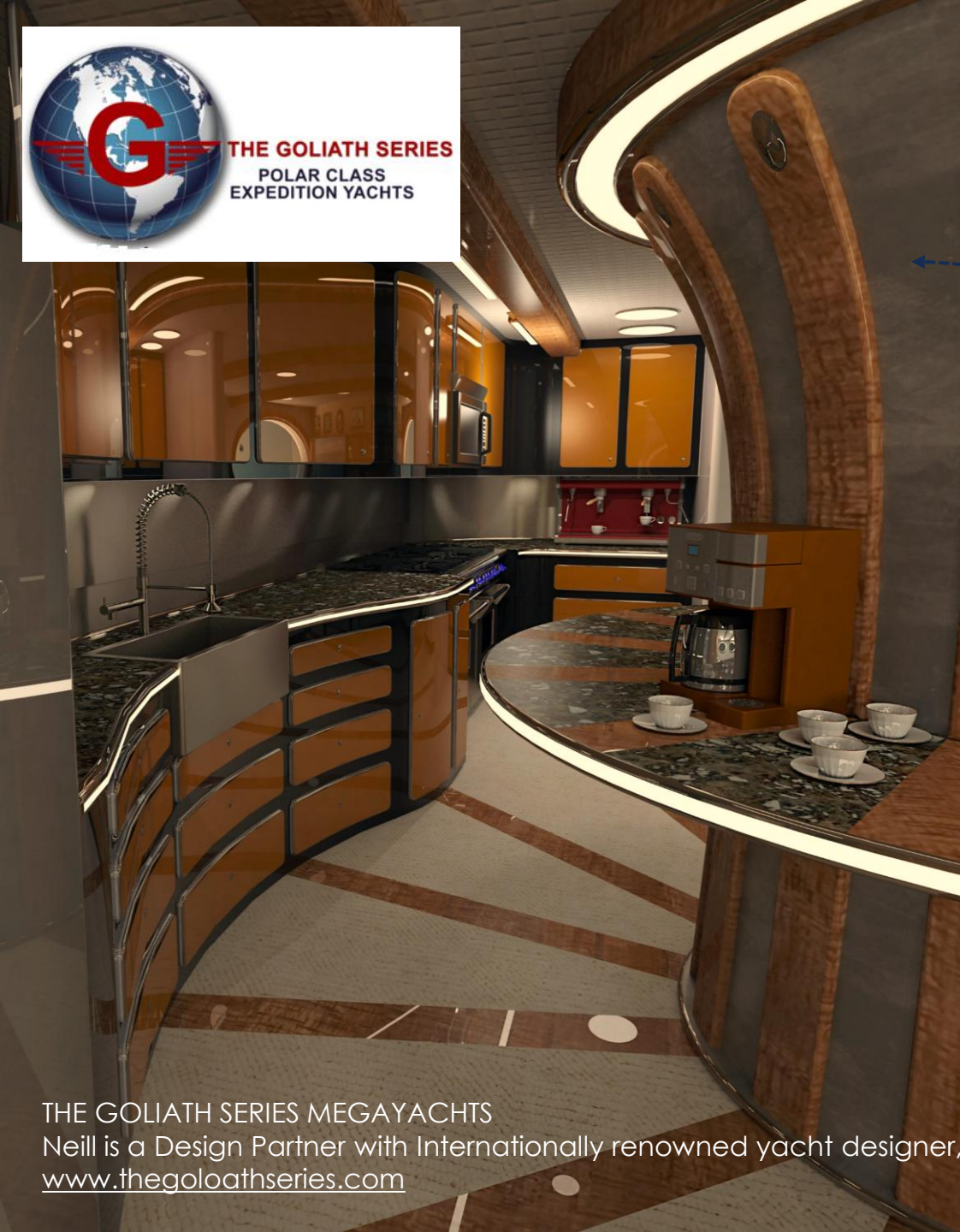

THE GOLIATH SERIES MEGAYACHTS
Neill is a Design Partner with Internationally renowned yacht designer, Steve Kozloff
www.thegoliathseries.com

August 2023

Current 'Couples' Superyacht Concept in Design Progress
www.thegoliathseries.com





NURSES TRAINING CENTRE CHRISTCHURCH
Polymer Piling





SOLAR AVIATION LIGHTING AND MODULAR BAGGAGE HANDLING AND SCREENING SYSTEMS FOR REMOTE LOCATIONS



SECURITY CONSULTANT & CONTRACTOR

APAC Surveillance provide turnkey supply, install and maintain services for our world class Airborne, Ground and Ocean based security systems across the APAC region.



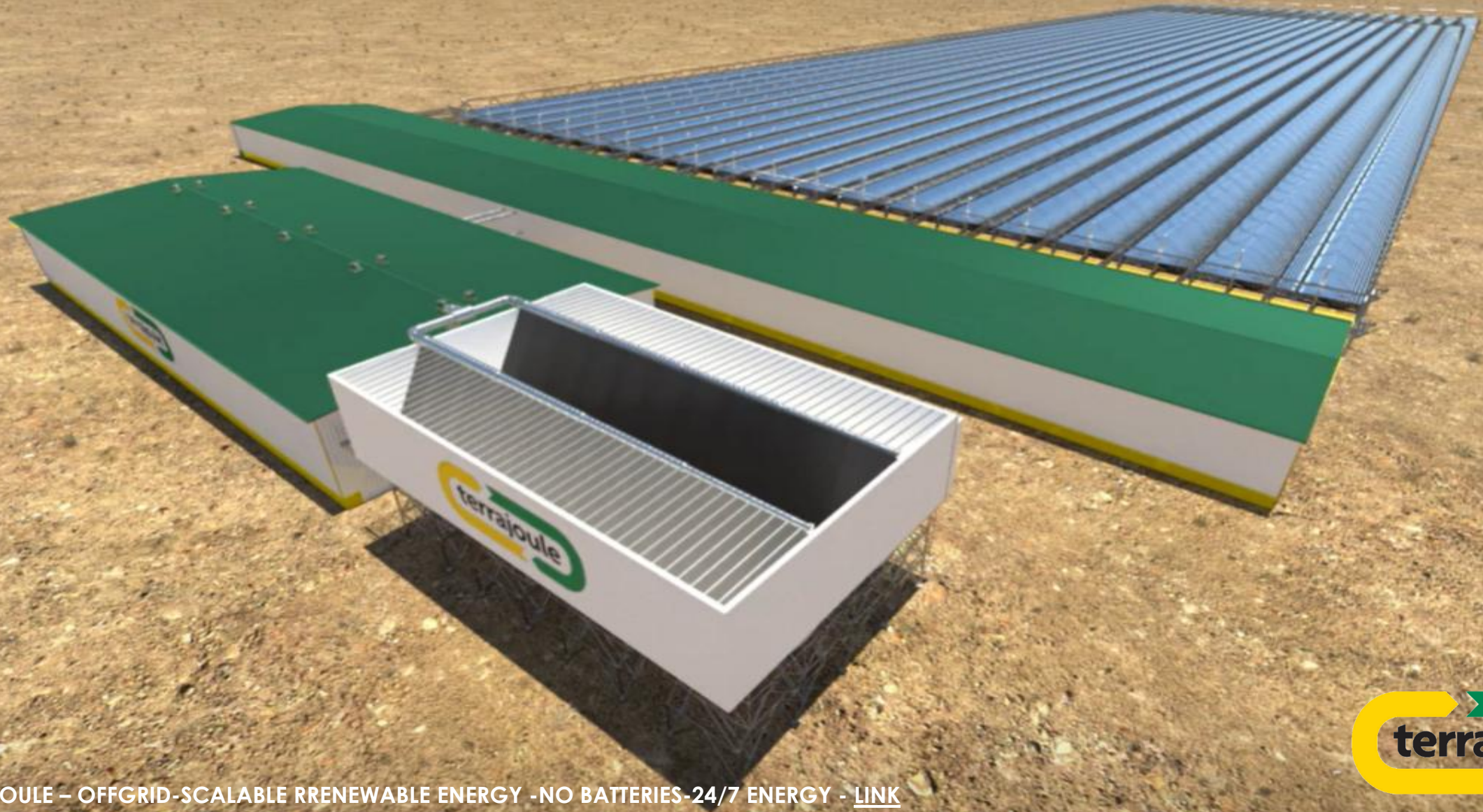

TERRAJOULE – OFFGRID-SCALABLE RRENEWABLE ENERGY -NO BATTERIES-24/7 ENERGY - [LINK](#)





NAYLOR LOVE – THE WAREHOUSE DISTRIBUTION CENTRES AND STORES

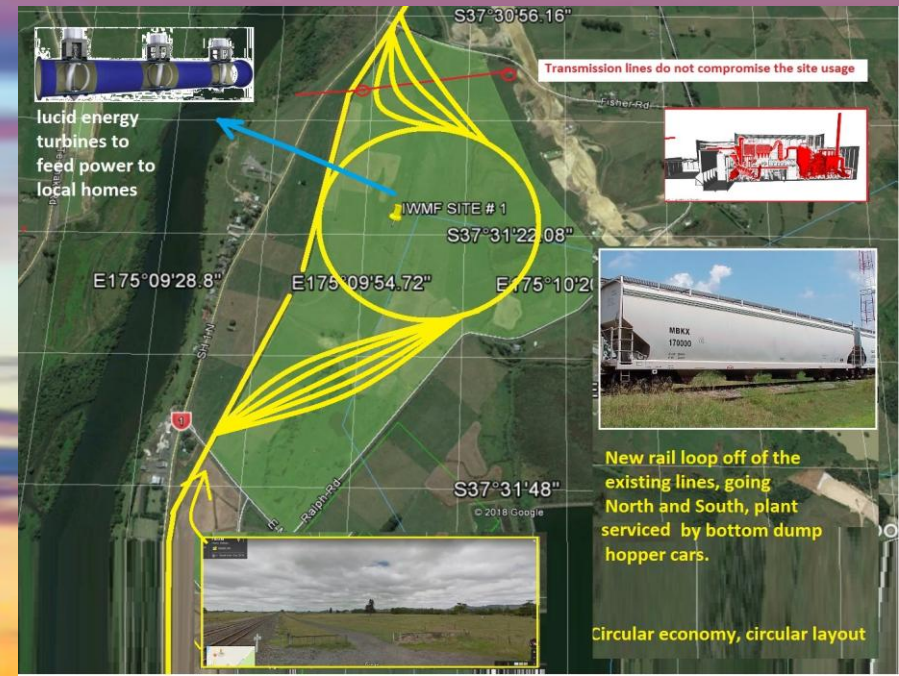

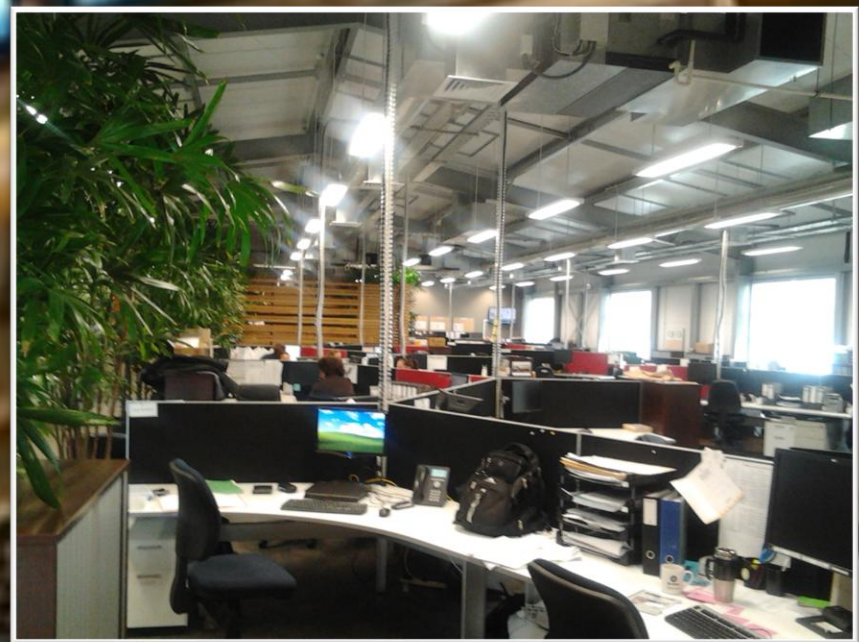

ST JOHN EMERGENCY CALL CENTRE – POST EARTHQUAKE BUILD

MIT TECHPARK - Overall Design Management, Programme and Budget management.

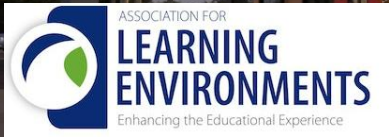



BATHROOM PODS

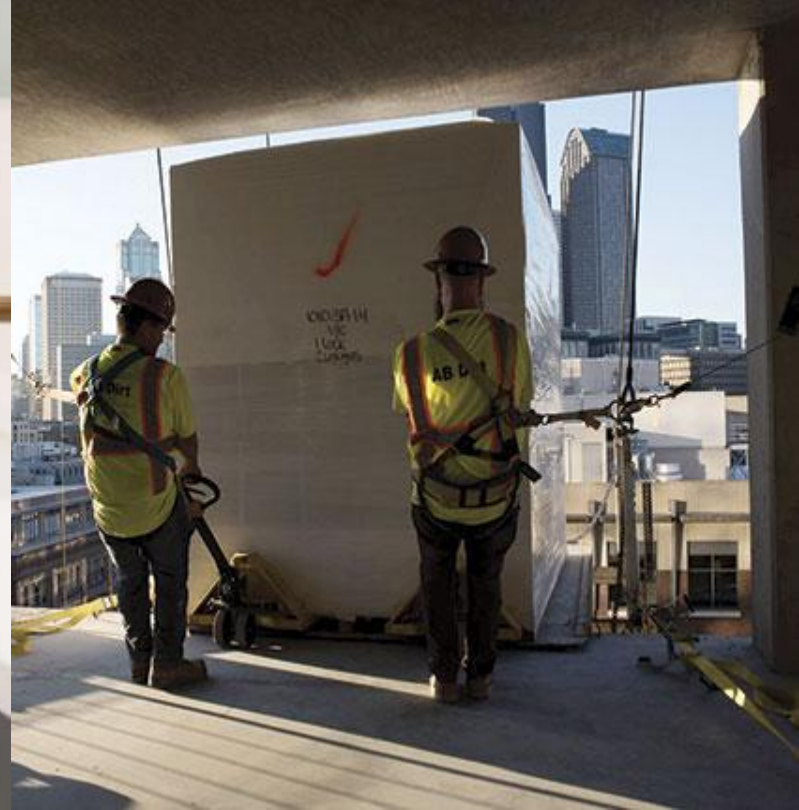

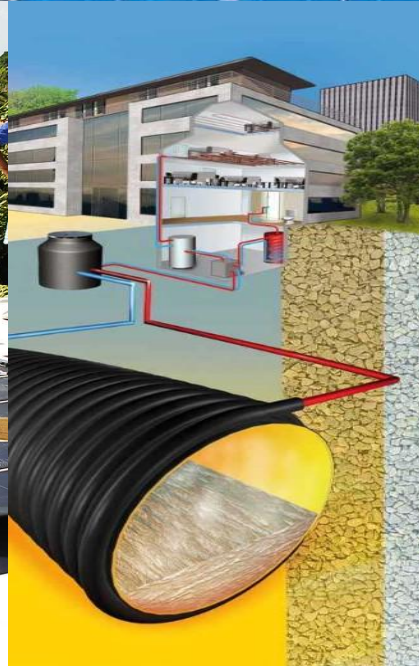



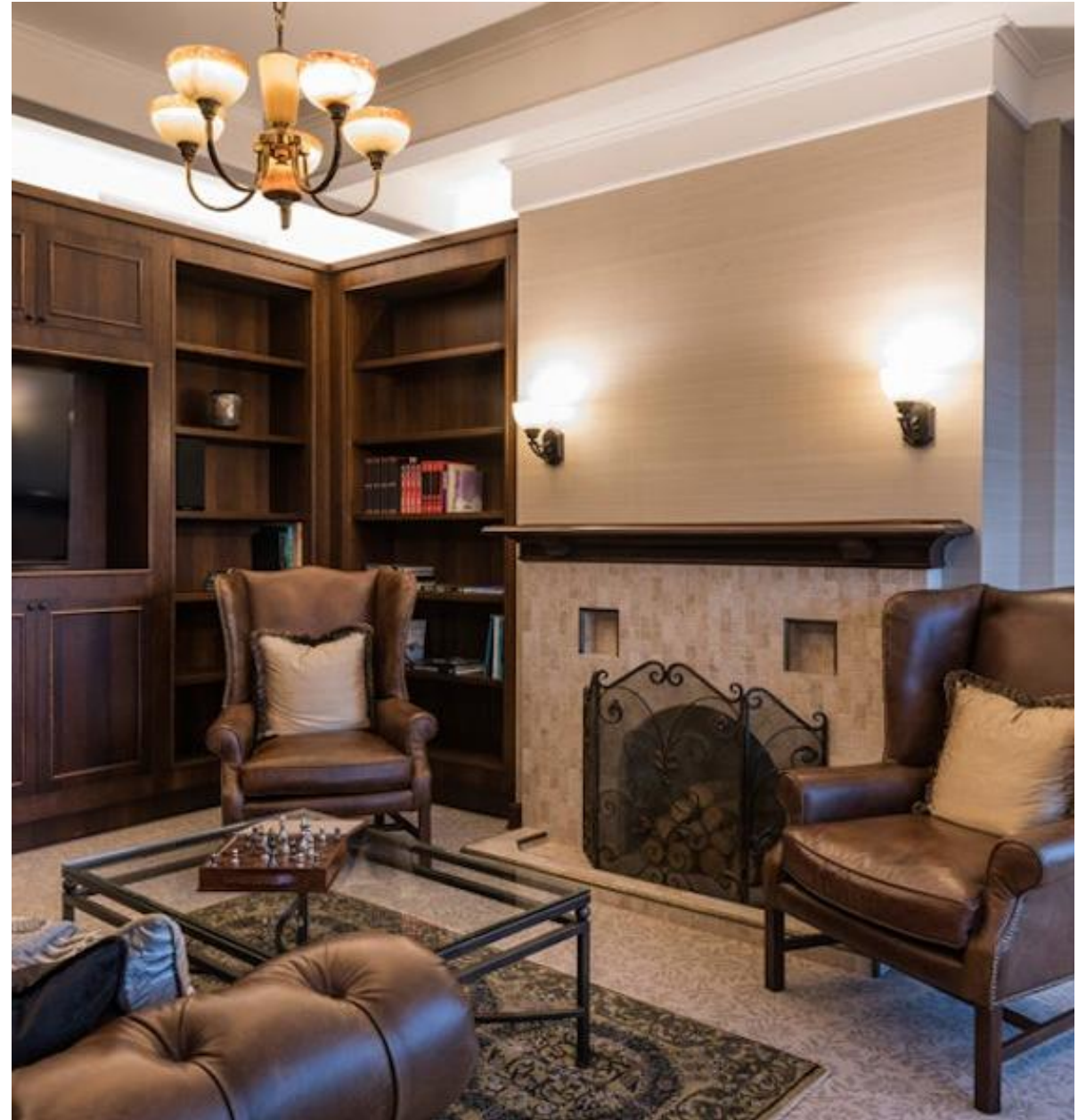

Hackthorne Gardens Luxury Accommodation in Christchurch has nine beautifully appointed guest rooms with stunning views of the city, the Southern Alps and the East coastline.



2018 Canterbury Architecture Awards Winner

Lintrathen Gardens consists of two luxury residential houses and eight luxury townhouses.



VILLA DA VINCI –KLAASENS ROAD BISHOPSCOURT CAPE TOWN





WAIMAKARIRI COUNCIL POOL – DUDLEY PARK





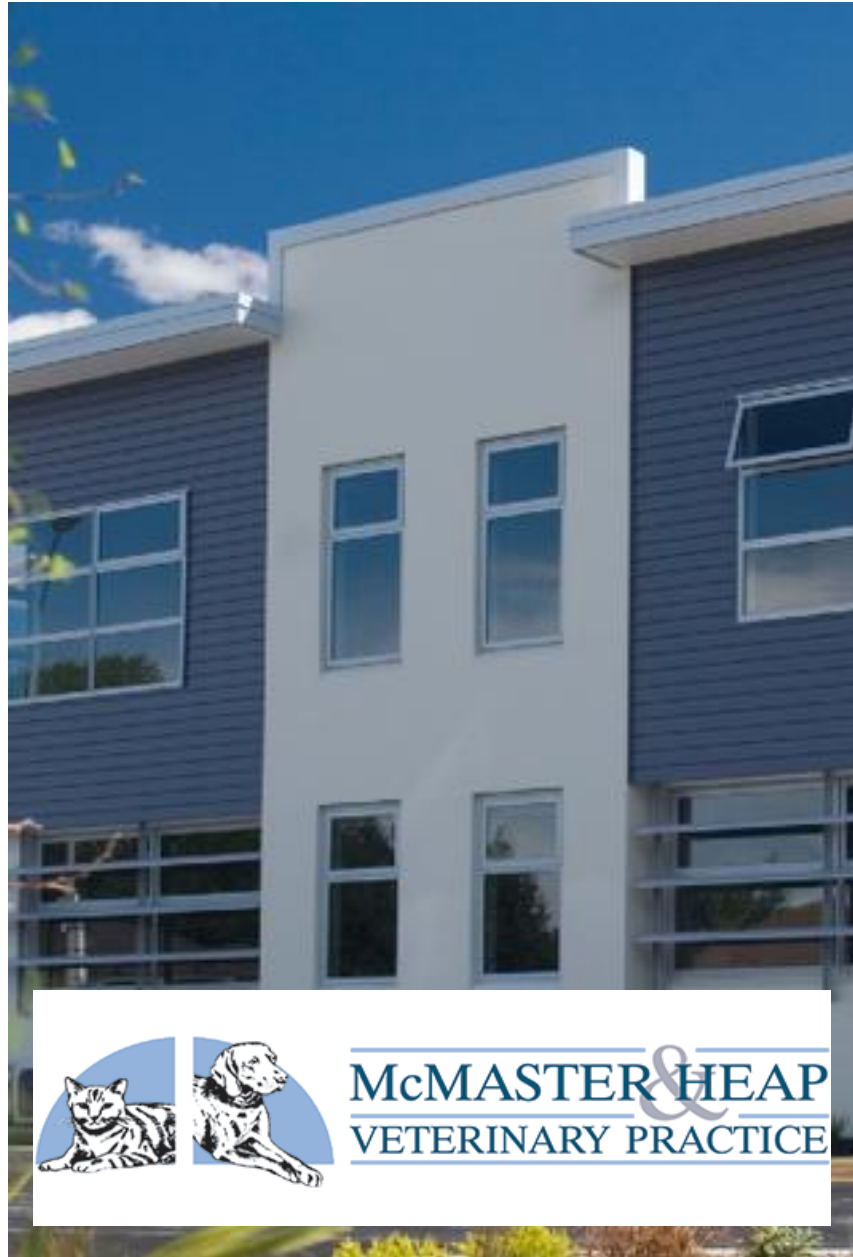
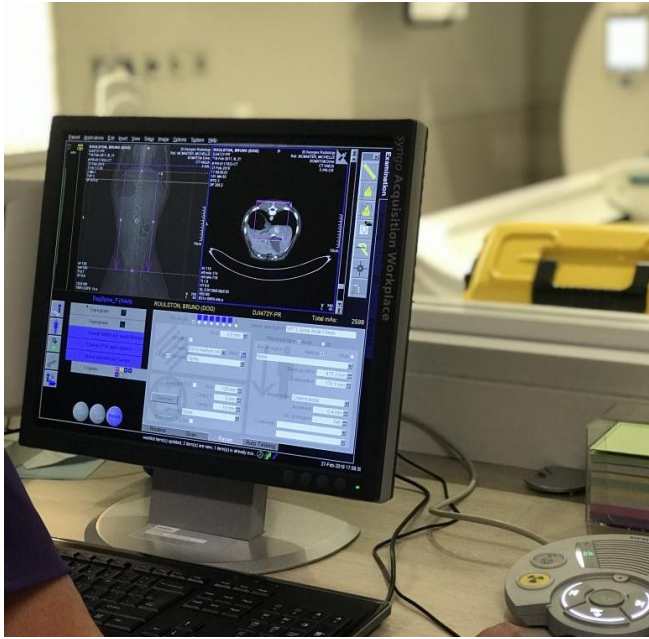



Hamasaki Memorial Residence – Japanese Bathroom - Terrace Downs, Canterbury

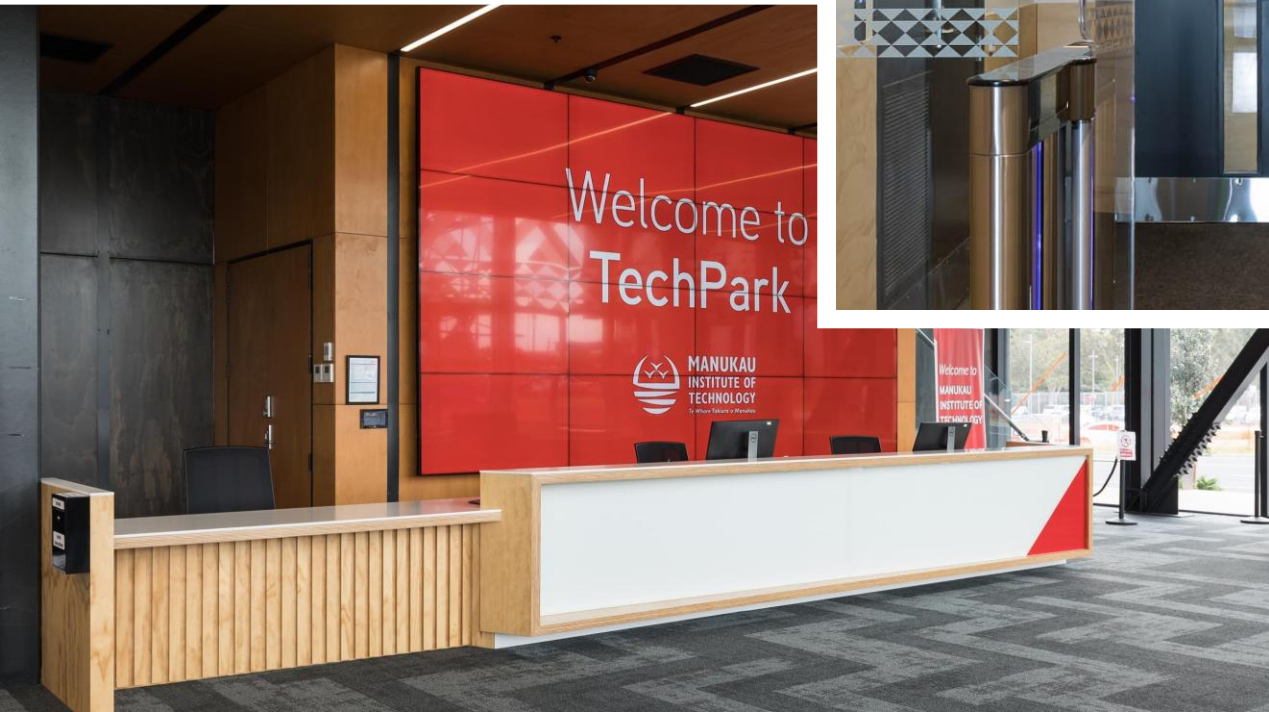
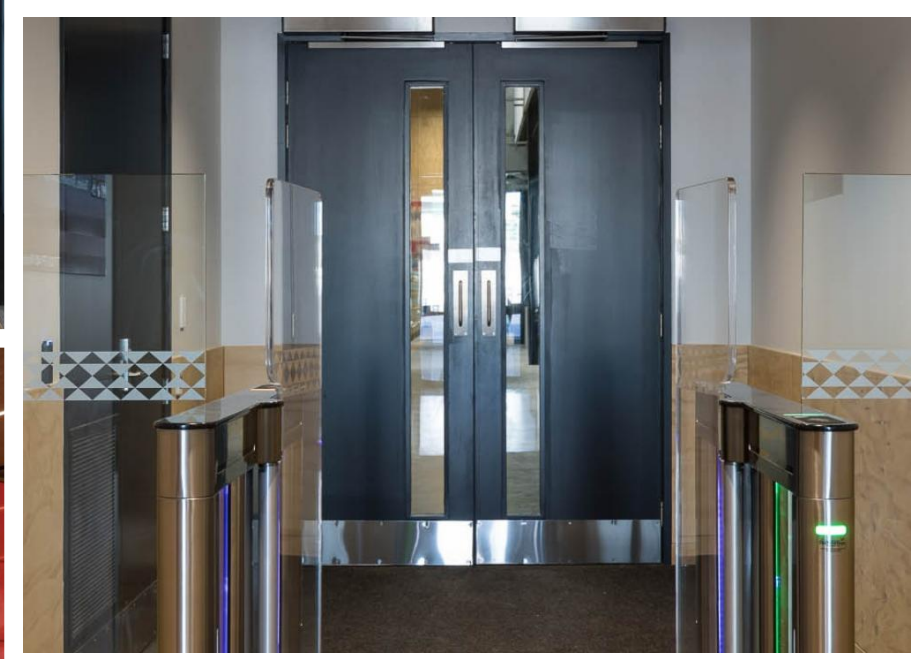

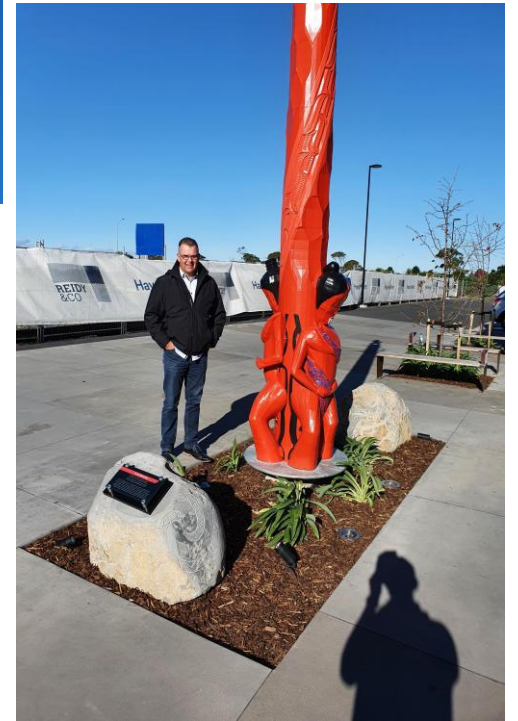
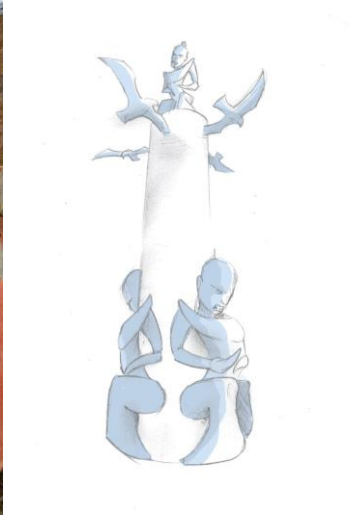

The World's first traditional indigenous 3D printed 'totem' (Māori Pou)

[LINK](#)



countdown



Gilmours

NEW WORLD – PAK n SAVE – FOUR SQUARE – COUNTDOWN - GILMOURS

Innovative Renewables

Heller Residence –
Marlborough Sounds
New Zealand - Flisom
CIGS, in-Tray Light-
Weight Solar panels.

Architects: Ian
Cumberpatch

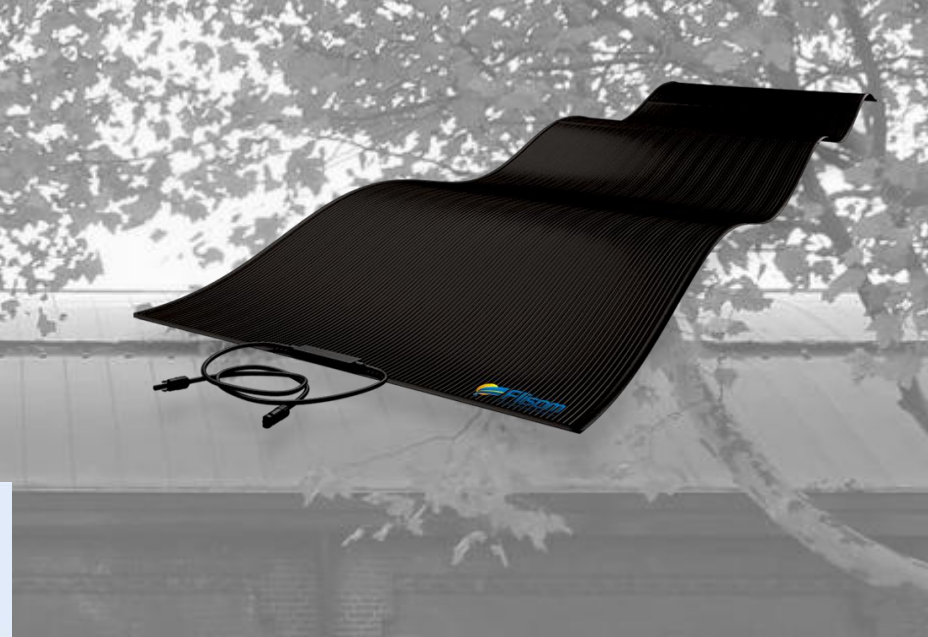
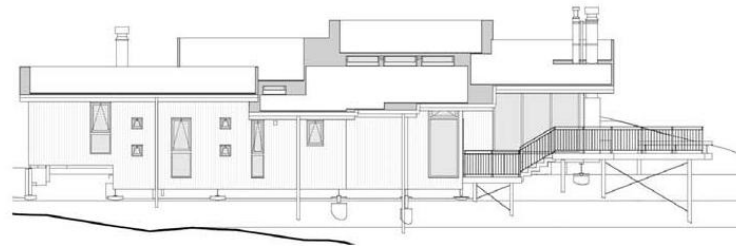



**VILLA DA VINCI –KLAASENS
ROAD
BISHOPSCOURT
CAPE TOWN**

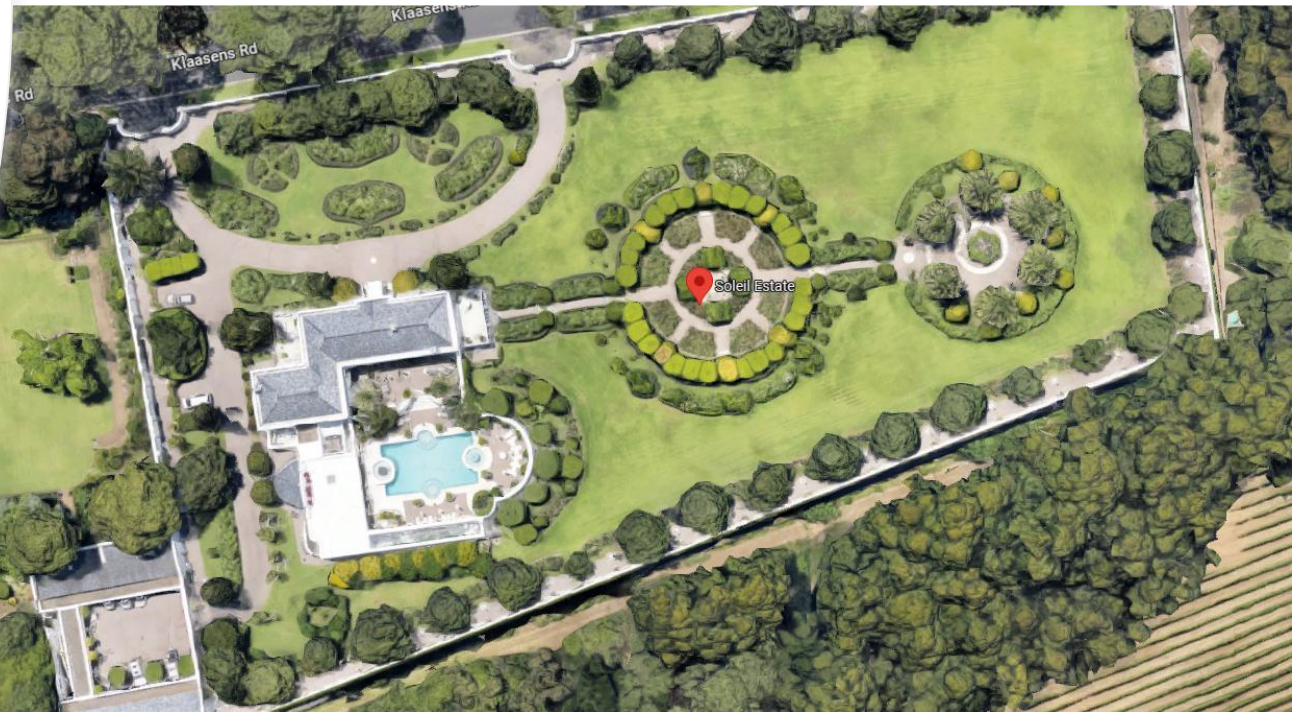

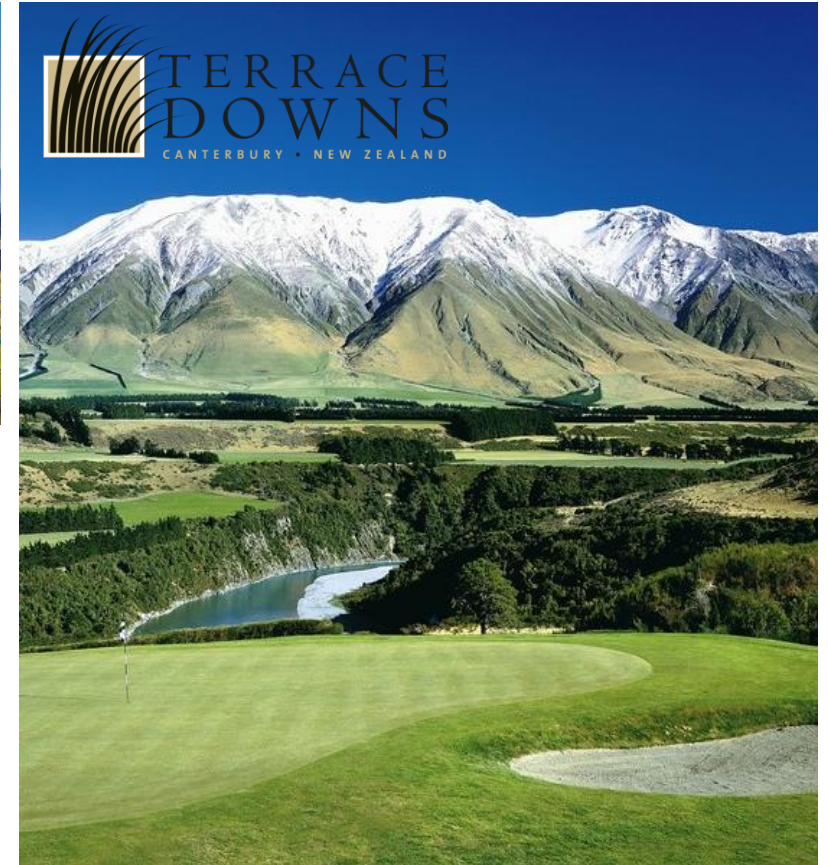

PEGAUS GOLF CLUB – CANTERBURY NEW ZEALAND

TERRACE DOWNS GOLF RESORT – CANTERBURY NEW ZEALAND

STEENBERG ESTATE – CAPE TOWN SOUTH AFRICA

Lecture Theatres / Cinema Auditoriums

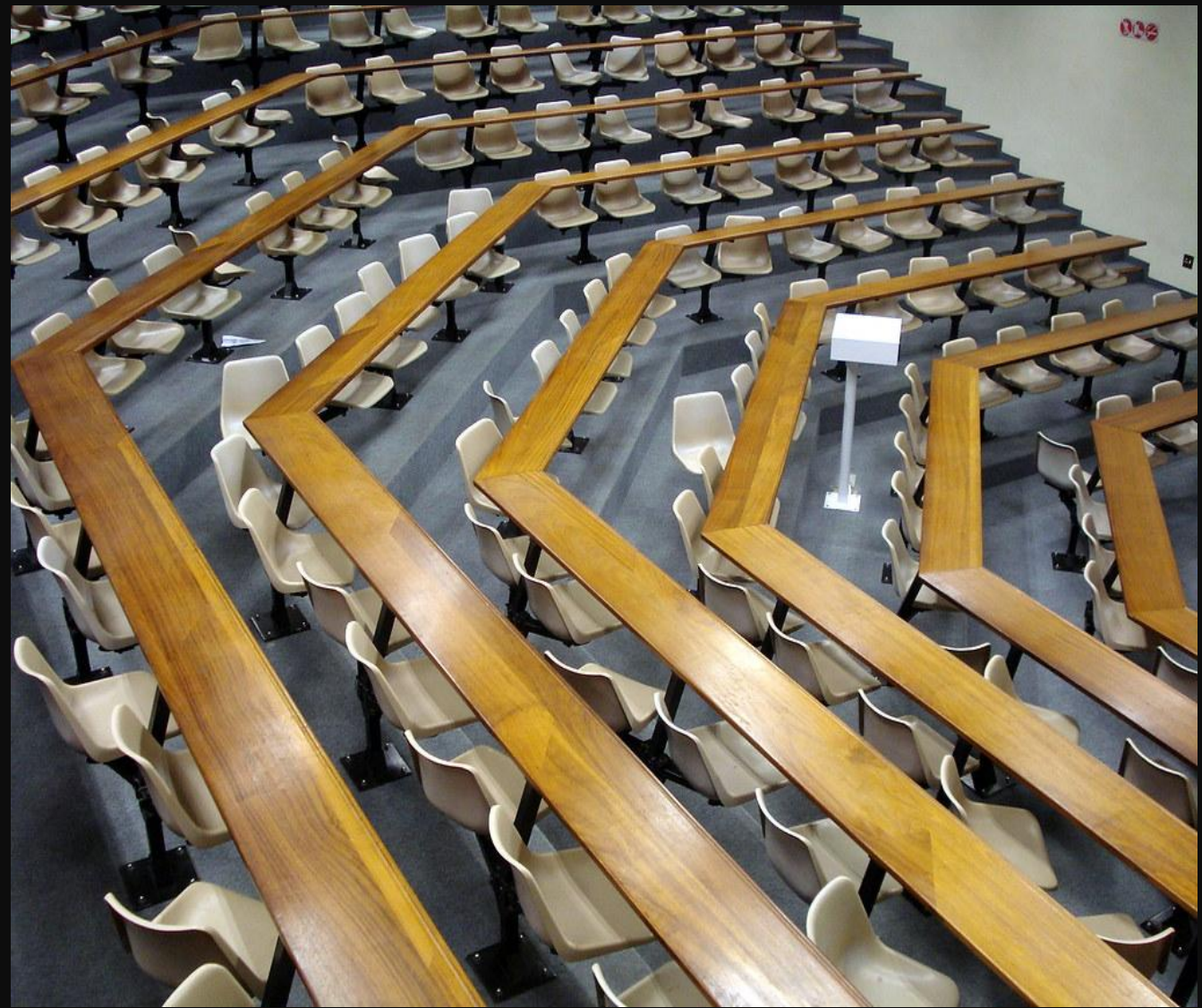



Four Square
(Foodstuffs New Zealand)
rebranding and
new stores roll-
out.





STEENBERG GOLF ESTATE - CLUBHOUSE



STEEBERG WINERY





SKYCITY CASINO
Gaming floor 'pit' changes, balcony extensions, Member Club construction and services reconfiguration.

SKYCITY CASINO FITOUT
Member Club
construction and
services reconfiguration
of internal escalators,
within an operating
casino environment.
Working with the
Government agencies
to verify and check
compliances.

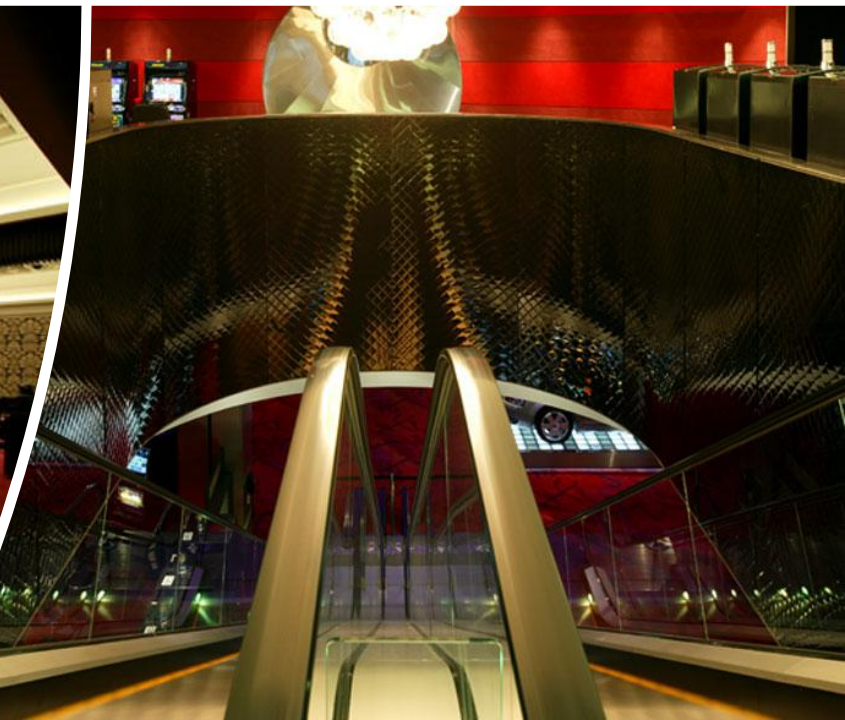



FACADES



Frozen and Chilled '[ASRS](#)' warehousing, Tannery - Preconstruction Phases, planning, design coordination, programming and budgeting

Medical Fitout





STENBERG GOLF ESTATE – HOTEL & RESTAURANTS



FACADES AND LARGE SACLE SKYLIGHTS



TERRACE DOWNS.

Multiple resort projects and infrastructure projects – Feasibilities and design concepts.



FOOD PREPARATION AND
PROCESSING FACILITIES
CLEAN ROOM POSITIVE
PRESSURE ENVIRONMENTS



VIRGIN ACTIVE GYM – KENILWORTH CAPE TOWN
Mall developer – Design and Build contract





Shiitake mushroom 'farm'



AUSCO MODULAR – BRISBANE
Manufacturing Manager

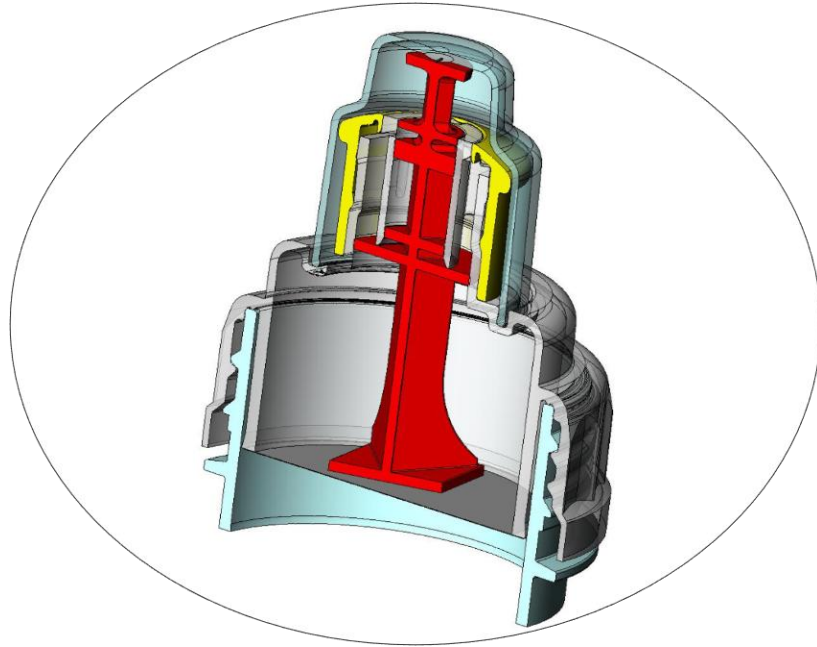

PRODUCT DEVELOPMENT
MANUFACTURING FACILITY PLANNING

- Concept dosed water and milk powder, compostable baby bottle
- Bottling plant design
- Bottle design
- Label design
- International liaison with product developers
- Local coordination of product design
- Pure Spring water product design
- Pure Vodka bottle design





TIMBER LVL COMMERCIAL BUILDINGS

THOM
CRAIG
ARCHITECT

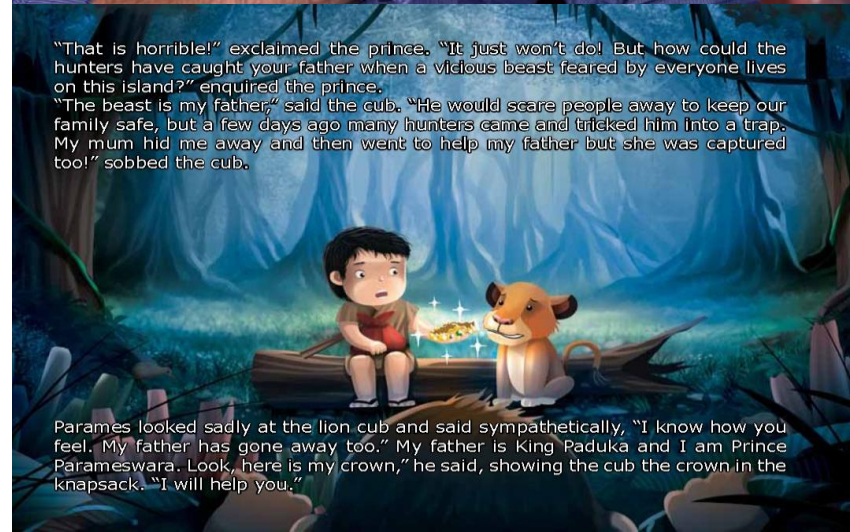

Neill Laurenson
M - +61 (0) 488 061 292

